



2021



**INDIAN NATIONS
FOOTBALL CONFERENCE**



**FOOTBALL
RULE BOOK**

INDIAN NATIONS YOUTH FOOTBALL

Indian Nations does not condone, support or tolerate harmful and/or berating language, assaults, speech or battery towards any game official, director, staff, coach, parent or player. Those attending who choose to exhibit such behavior may be immediately and/or indefinitely removed from any Indian Nations event.

OKLAHOMA STATUTE REGARDING HARM TO OFFICIALS

Oklahoma Stat. Ann. Tit. 21, Section 650.1 provides: Every person who, without justifiable or excusable cause and with intent to do bodily harm, commits any assault, battery, assault and battery upon the person of a referee, umpire, timekeeper, coach, official, or any person having authority in connection with any amateur or professional athletic contest is guilty of a misdemeanor and is punishable by imprisonment in the county jail not exceeding one year or by a fine not exceeding One Thousand Dollars (\$1,000) or both such fine and imprisonment.

For more information visit www.youthsports.com



FOOTBALL RULE CHANGES - 2021

By NFHS on May 27, 2021

Action in the Free-Blocking Zone [2-17-2c (NEW), 2-17-4]

Blocking below the waist now requires the block to begin immediately following the snap.

2021 EDITORIAL CHANGES

Changes reflected within the 2021 National Federation of High Schools (NFHS) football rulebook.

1-5-1b(3); 2-10-1; 2-10-2; 3-5-1; 9-4-4 PENALTY, NINE-, EIGHT- AND SIX-PLAYER RULES DIFFERENCES – GENERAL; SIX-PLAYER RULES DIFFERENCES – RULES 2 and 7

2021 POINTS OF EMPHASIS

- Sportsmanship
- Intentional Grounding
- Ineligible Downfield and Line of Scrimmage Formation

TABLE OF CONTENTS

INFC BY-LAWS

Section 1-3	Organization/Club/Membership	1
Section 4	Officers	3
Section 5	Committees	5
Section 6	Meetings	6

INFC GENERAL RULES

Section 7	Coaches Certification	7
Section 8	Coaches	8
Section 9	Equipment	8
Section 10	Rule Violations	9
Section 11	Protests	10
Section 12	Player rules/participation	12
Section 12-B	Age/grade requirements	13
Section 13	Team Drafts	14
Section 14	Transfers, Releases & Waivers	16
Section 15	Football Rules	17
	Article 2 Officials	17
	Article 3 Practices	18
	Article 4 Camps	19

	Article 5 Labor Day Holiday	20
	Article 6 Scheduling/Forfeits	20
	Article 7 Length of Game	20
	Article 8 Mercy Rule	21
	Article 9 Unsportsmanlike Kick	21
	Article 10 Kick Off	21
	Article 11 Scoring PAT	21
	Article 12 Reporting Scores	21
	Article 13 Half-time Procedures	21
	Article 14 Press box procedures	22
	Article 15 Gate Admission	22
	Article 16 Chains	22
	Article 17 Radios	22
	Article 18 Cameras	23
	Article 19 Free Blocking Zone	23
<u>Section 16</u>	Weight Limits	24
	Article 2 Striped players	24
	Article 3 Weight Limits/scales	26
	Article 4 Weigh-in	26
<u>Section 17</u>	INFC AA League	28
<u>Section 18</u>	Post-Season Games	28
	Article 1 General Play-Off Info	28
	Article 2 Marginal Points	29
	Article 3 Play-Offs	29
	Article 4 Division Tie-Breakers	29
	Article 5 Championships	29
<u>Section 19</u>	Special Rules for 3rd/4th Grade	30
	Article 1 Participation	30

	Article 2 Center Protected	30
	Article 3 Limited on Field Coaching	30
	Article 4 20/20 Punt	30
	Article 5 Practice	30
	3rd – 7th Grade Post-Season Tournament	31
Section 20	Rules Governing Overtime (Tiebreaker)	33
	Article 1 Overtime Tiebreaker (playoff)	33
	Article 2 Overtime Tiebreaker (regular)	33
Section 21	Rules Changes	33

MIGHTY MITE FOOTBALL

ADDITIONAL GOVERNING RULES

Section 1	Purpose	35
Section 2	General Information	35
Section 3	Coaches & Parents Rules	35
Section 4	Drafts	36
Section 5	Player Participation Rules	37
	Article 1 Rosters	37
	Article 2 Participation	37
	Article 3 Weight Limits	38
	Article 4 Weigh-in Procedure	39
Section 6	Game Rules	39
	Conduct	41

Section 7	Defense	42
Section 8	Offense	45

CHEERLEADING BY-LAWS

Section 1	Purpose	49
Section 2	Cheerleading Council	49
Section 3	Election of INFC Cheer Director	50
Section 4	Membership	50
Section 5	Rules & Regulations	51
Section 6	Rule Violations	51
Section 7	Certifications & Clinics	52
Section 8	General Coaches Rules	53
Section 9	Participation Rules	54
Section 10	Practice and Member Conduct	55
Section 11	Stunt Regulations/Guidelines	56
Section 12	INFC Tackle Gate	57
Section 13	Half-Time Performance	57
Section 14	Music	58
Section 15	Competitions	58
Section 16	General Safety Guidelines	58
	Cheer Stunt Guide	59
Section 17	Cheer Etiquette	60
Section 18	Rule Changes	61

Club Membership Contacts	62
---	-----------

INFC Directors Officers & Staff	68
--	-----------

Signs & Symptoms of Concussion	70
---	-----------

Parent Code of Ethics	72
--	-----------

Official Football Signals	73
--	-----------

Indian Nations Football Conference By-laws

Section 1 The Organization

The name of this organization shall be Indian Nations Football Conference (INFC), a subsidiary of Indian Nations Youth Sports.

The Conference was organized by member organizations on January 20, 1986.

The purpose of the Conference shall be to govern, coordinate and enforce the INFC by-laws for all organizational events among the participating organizations and their individual members.

CLUB MEMBERSHIP

Article 1: Membership in this Conference shall consist of the following organizations listed below.

Article 2: By accepting the terms of membership in the Indian Nations Football Conference (INFC) Member organizations and their individual members acknowledge that the INFC is a private organization and that it reserves the right to refuse membership and/or participation to any person whose actions hinder the activities or violates the rules of the INFC and that such determination will be at the sole discretion of the INFC.

Bartlesville YMCA	Berryhill Little Chiefs	Bixby Youth Football
Broken Arrow Youth Football	Catoosa Youth Football	Choctaw Youth Football
Claremore Youth Football	Collinsville Youth Football	Coweta QB Club
Edmond Youth Football	Fort Gibson Youth Football	Glenpool Youth Sports Inc.
Grove Youth Football	Hilldale Youth Football	Jenks Trojan Athletics
Junior Comets Youth Football	Lincoln Christian School	McAlester Youth Football
Metro Christian	Muskogee Youth Football	Norman Optimist Club
Owasso F.O.R.Piedmont Youth Football	Sand Springs Youth Football	
Sapulpa Little Chiefs	Skiatook Bulldog Football	Stillwater Youth Football
Tulsa Yellow Jackets Football	Tulsa Youth Athletic Assoc.	Union Youth Football
Verdigris Youth Football	Wagoner Bulldogs	Westmoore Youth Football

Arbitration

It is agreed that any matter in dispute between (i) you and/or individual members and (ii) the Indian Nation Youth Sports (INYS) and its subsidiaries shall be subject to arbitration as an alternative to court action pursuant to the rules of the American Arbitration Association, a copy of which is available on request from the company. Any decision reached by Arbitration shall be binding upon both you and the INYS and shall be enforced at a Judgment in any court of proper jurisdiction. The Arbitration award may include attorney's fees if allowed by state law and may be entered as a judgment in any court of proper jurisdiction.

Attorney fees

If Indian Nations Youth Sports prevail in any litigation or arbitration brought arising from any dispute, then the INYS shall be entitled to recover all costs, expenses and attorney's fees associated therewith.

Section 2

Annual dues of all members shall be determined annually by a majority vote of the membership. The annual dues shall be \$200.00 per team plus \$200.00 annual club fee. Each member prior to the first game of the season shall pay all dues. A \$10.00 per day late fee will be assessed on any member not current. Exceptions must have prior approval by the Commissioner.

Section 3

Article 1: No new member shall be admitted into the INFC whose proposed recruiting territory includes or overlaps any portion of the recruiting territory of an existing INFC member club. An existing INFC member may reassign a portion of their recruiting territory to a prospective INFC member by submitting their approval of the recruiting territory realignment in writing to the INFC membership for approval.

All recruiting territory disputes/clarification issues between existing INFC members will be resolved by the INFC Commission.

Article 2: To be a member of *Indian Nations Football Conference*, all current and prospective member organizations must detail and submit the following documents in writing annually to the conference for review:

- The structure of their organization including club By-Laws and/or corporate governance.
- The officers of their organization along with personal contact information for each Board Member.
- The area(s) requesting protection of players via the INFC territory report.

An organization wishing admittance must require its individual members to adhere to INFC by-laws and rules and must have a minimum of 3 teams in different grade levels. A commission representative will inspect the playing field for approval.

Article 3: To be a member of Indian Nations Football Conference the organization asking to be admitted must receive two-thirds vote of approval by the member organizations.

Article 4: An organization, after having been newly admitted in the *INFC*, shall be required to sign an *INFC* member contract and will automatically be placed on two (2) year's probation. Probation begins the date the *INFC* contract is signed by both parties. Each new president voted into the organization will be required to review and sign the existing contract.

Article 5: Expulsion of a member organization during the probation period shall require only majority vote of the remaining member organizations. The expulsion of an organization not on probation shall require two-thirds vote of the remaining members.

Article 6: *INFC* member organizations shall not have tackle football teams or players participate in any other conference or league. Those clubs grandfathered as an exception to this rule will not be allowed to play any Mighty-Mite team outside their organization.

Article 7: All member clubs must register all participants (football, cheer, etc.) using the *INFC* approved online database, Sportabase.

Section 4

INFC Officers

Article 1: The Officers of the *INFC* shall be referred to as the "Commission" and shall be comprised of a Commissioner, 1st Vice Commissioner, Secretary/Treasurer, Seventh Grade Director, Sixth Grade Director, Fifth Grade Director, Fourth Grade Director, Third Grade Director, and Mighty-Mite Director.

Article 2: The Commissioner shall be a hired position by the *INFC* Membership. All the other Officers will be elected by majority vote during the spring membership meeting and will serve a one year term. No more than two officer positions can be filled by any member organization.

Section 4-B

Commission Officers

Tulsa Commissioner: The Tulsa Regional Commissioner shall preside at all Tulsa region meetings, appoint sub-committees, and administer and enforce all rules and activities of the *INFC*. The Tulsa Commissioner will be empowered with all rights to make immediate rulings on questions of rule violations or questions raised from incidents not covered by *INFC* rules and regulations within the Tulsa region. His ruling will stand until which time the *INFC* Commissioner, Vice-Commissioner and/or Officers making up the Commission can meet. The *INFC* Commissioner, Vice-Commissioner and Commission can then overturn the Tulsa Commissioner or reinforce the Tulsa Commissioner's decision by a majority vote of the Commission.

Oklahoma City Commissioner: The Oklahoma City (OKC) Regional Commissioner shall preside at all OKC region meetings, appoint sub-committees, and administer and enforce all rules and activities of the *INFC*. The OKC Commissioner will be empowered with all rights to make immediate rulings on questions of rule violations or questions raised from incidents not covered by *INFC* rules and regulations within the OKC region. His ruling will stand until which time the *INFC* Commissioner, Vice-Commissioner and/or Officers making up the Commission can meet. The *INFC* Commissioner, Vice-Commissioner and Commission can then overturn the OKC Commissioner or reinforce the OKC Commissioner's decision by a majority vote of the Commission.

Tulsa Vice Commissioner: The Tulsa Regional Vice Commissioner is an elected position that will serve as a voting member of the *INFC* commission and be empowered to enforce and uphold the rules of the conference. The Tulsa Vice Commissioner shall perform the duties of the Tulsa Commissioner during his/her absence.

Oklahoma City Vice Commissioner: The Oklahoma City Regional Vice Commissioner is an elected position that will serve as a voting member of the *INFC* commission and be empowered to enforce and uphold the rules of the

conference. The OKC Vice Commissioner shall perform the duties of the OKC Commissioner during his/her absence.

INFC Historian: The *INFC* historian is an elected position and will be empowered to enforce all rules of the *INFC*. He/she will work with the Secretary to ensure accurate accounting of the minutes and be ultimately responsible for the procurement of all conference data, archiving of *INFC* information and reporting on said information.

Secretary/Treasurer: Is an elected position and will be empowered to enforce all rules of the *INFC*. He/She will record accurate minutes of all *INFC* meetings, maintain an up to date accounting of all *INFC* Financial matters, and attest to all contracts, mortgages, deeds, and similar instruments of the *INFC*. He/She shall be responsible for the filing of all taxes and/or accounting forms as may be required by this corporation or any government agency. Checks written in excess of \$200.00 will require the signatures of any two Officers.

Grade Directors: For 1st through 7th grades there shall be an elected commission officer appointed to each grade. Each Grade Director will be empowered to enforce all rules of the *INFC*. Grade Directors will not be allowed to coach within the grade level in which they represent. He/She will monitor, represent, and coordinate that particular grade's tackle activities. He/She will assign four persons within this age group as coordinators to assist in these duties.

Cheer Director: Is an elected commission officer and will be empowered to enforce all rules of the *INFC*. He/She will monitor, represent, and coordinate the cheerleading activities.

Section 5

Committees

Article 1: The following committees will be formed each year.

Sportsmanship and Compliance Committee: Responsible for monitoring the conduct of parents, coaches, and players as well as reporting to the Commissioner for possible disciplinary actions.

Participation/Draft Committee: Responsible for overseeing member association drafts to insure the *INFC* draft procedures are properly adhered to.

The committee will also be charged with monitoring coaches regarding player participation. Violations must be reported immediately to the Commissioner.

Release Committee: Responsible for defining member organization recruiting areas as well as reviewing player request for transfers to and from an *INFC* organization outside their assigned playing territories. This committee will deliver to the Commissioner the committee's recommendations for review and assignment.

Special Events Committee: Responsible for overseeing special member association events such as Coaches conferences, drafts and championship games.

Section 6

INFC Meetings

Article 1: Meetings shall be held at the request of the Commissioner or at the request of any *four*-member Clubs within fourteen (14) days of such request. These meetings shall be limited to the individual member organization's representative, coaches and member organization officers; however, each organization will be limited to three active participants during any meeting. The Commissioner can grant exceptions. Persons other than those listed above wishing to attend a Conference meeting and/or address the membership must first have approval of the Commission or Commissioner.

Article 2: Each organization must be notified at least 72 hours in advance of any meeting and be given the purpose of the meeting. No Conference business can be conducted unless this condition is satisfied.

Article 3: Each organization shall have one vote PER GRADE LEVEL registered with *INFC* on any issue requiring a membership vote. Members having that grade level can only vote on issues relative to a particular grade. The number of votes per grade will be determined by the "declaration of teams" meeting and will be valid for one year. New members will be limited to 2 votes until the declaration of teams meeting. Member organizations without team representation in a particular grade will not vote on issues that apply to that grade.

Article 4: Members present and attending a Conference meeting that has been publicized to the *INFC* membership will constitute a quorum.

Article 5: Proxy votes will not be accepted at meetings. Members must be present to vote on Conference matters.

INFC General Rules

Section 7-A

Coaches Certifications

Article 1: Each head coach and all members of each coaching staff shall be certified in football by USA Football and show proof upon request. All certifications shall be issued by USA Football. The President of each member club will turn in to the INFC office a list of all coaches involved in their program along with their card number and contact information prior to the first regular season game. This will allow a current up-to-date list of all certified coaches to be maintained and on file in INFC office should any problems or questions arise.

Article 2: Exception to USA Football certification are:

- A. Another form of certification approved by the Commissioner
- B. OSSAA School Certified Coaches

Article 3: **All Coaches while at weight-in & on the sideline must wear a copy of their current years football certification on a lanyard around their neck.**

Article 4: All coaches within the INFC must be registered on the Sportabase registration system before being allowed to participate in practices or games. Those in violation will be immediately removed from coaching and are subject to fines and/or penalties.

Section 7-B

Coaches Background Verification

Article 1: All coaches must undergo a background verification through the club for which they are coaching. Each individual club is responsible for establishing their criteria.

Section 8

Coaches

Article 1: The head coach is responsible for their sideline. If a coach is not wearing the certification, the coach in question will be removed from the sideline and prohibited from coaching.

Article 2: The number of non-player personnel on each football team's, sideline shall not exceed a total of eight (8). This eight includes coaches, manager, play counters, & water aids. Any coaching of players must be by a certified coach. The Head coach will be held accountable for their sideline personnel and all violations of this rule.

Article 3: One coach from each team must attend the mandatory coaches meeting. Failure to comply will result in a \$200.00 team fine. All games will be forfeited until such fine is paid to INFC. Persons caught in an attempt to falsify attendance for another coach will be suspended for the season.

Article 4: **All new coaches must attend an INFC orientation** prior to the first INFC scheduled game. **Failure to attend will result in that person being removed from coaching for that season.**

Article 5: All members must furnish a copy of INFC By-laws and rules to all tackle head coaches, cheerleading head coaches, and club officials of their organization each season. Failure to comply will incur a \$200.00 club fine on each occurrence.

Section 9

Equipment

Article 1: Size of footballs (composite, leather):

Teams must start with and use the same size ball throughout the entire game for their appropriate grade level.

MM, 3rd, 4th and 5th grades — Regulation Pee-ewe size or larger

6th and 7th grades - Regulation Junior size or larger

Article 2: Oklahoma High School rules regarding player jersey numbers will not be enforced except that no two-team members with the same jersey number can participate in the game at the same time. Players must weigh in wearing that game's specified jersey. **No players shall change the jersey after weigh-in.** Violations will result in the involved players being declared illegal participants and may result in a forfeit by the offending team. Coaches involved in an intentional act of deception will face suspension by the Commission and/or Commissioner.

An exception to this rule can be made in the event of damage to a numbered jersey that renders the jersey unsafe for play provided that the game officials and opposing head coach are notified prior to the numbered jersey change.

Article 3: If opposing teams have similarly colored uniforms to the extent that game officials determine that team identification is an issue then the home team will wear target/practice jerseys provided by the hosting organization. If a team can produce a different color set of jerseys a jersey number change must be submitted to the opposing coach.

Article 4: Football cleats must be rubber. Steel, aluminum, or nylon with metal caps are illegal.

Article 5: All mouthpieces must be colored. All visors worn must be clear.

Article 6: Playing fields must be maintained in a safe condition. The INFC has the right to inspect playing fields and require they be maintained to a safe condition. Failure to comply will result in moving games to a suitable location until such time the field becomes compliant.

Section 10

Rule Violations

Article 1: Violations of *INFC* rules will be acted on and penalties assessed by the Commissioner and reviewed by the Commission, which at that time can, by majority vote, overrule or reinforce the Commissioner and his actions. The penalty or penalties assessed against an organization, coach, parent or player can be one or more of the following:

- Fine
- Forfeiture of game or games

- Suspension of coaches or individuals within an organization
- Probation
- Any action deemed appropriate by majority vote of the Commission including the permanent removal from the INFC.

Article 2: Fines assessed to players, parents, coaches, teams and/or organizations resulting from activities at INFC events shall be payable to Indian Nations Football Conference. Distributions (if any) of such payments deemed payable shall be paid from the INFC to the obligated organization(s).

Article 3: Assaults, verbal abuse, profanity, display of poor sportsmanship or rule violation by a coach, parent, participant, club official or guest at an INFC function will not be tolerated. Alcoholic beverages, illegal drugs or the consumption of either is not allowed at an INFC event. Penalties will be dealt accordingly.

Article 4: Any coach, player or spectator ejected from an INFC event will be automatically suspended for the next INFC scheduled game. Suspended coaches and players may be allowed to attend team practice. Suspended players are required to attend the suspension game with their team but are not to dress out. Suspended coaches will not be allowed to attend the suspension game, even as a spectator.

The INFC Commission and/or Commissioner may, at their discretion, review the circumstances surrounding a coach or player's ejection and adjust penalties as they deem warranted.

Article 5: A club **must** submit an incident report immediately to the Commission office involving team violations of the participation rule or any other violation of the Bylaws or be **subject to a club fine issued by the INFC.**

Section 11

Protests

Article 1: To protest an action or game by a coach to the Commissioner, the coach or persons involved in the incident must do the following within 48 hours of the incident:

- Submit a written statement on the incident in protest to their home

club's *INFC* Representative

- Attach a check in the amount of \$100.00 and any evidence pertaining to the incident.

Once the Commission has received and reviewed the written incident statement from the protesting member organization, they will then determine the appropriate ruling action. The protest fee will be refunded to the team or individual protesting only if the Commission rules in favor of the Protest. At the point the commission rules in favor of the protest, the team and/or individual then in violation of the protest will be assessed the full value of the current protest fee in addition to any subsequent action taken by the commission. Despite any additional action taken by the commission, the individual and/or team will not be allowed to take the field until such time as the fine has been paid in full.

Article 2: Protesting the Commission: To protest the action of the Commission, an organization must do the following within 72 hours of notification of such ruling:

- Submit a written statement with all relevant information pertaining to the incident's action and protest
- Attach a protest fee, in the form of a check, in the amount of \$400 and submit to the Commissioner.

The Commissioner will call for a protest committee meeting, comprising of one member of each membership organization to meet within fourteen (14) days. Only those parties with testimony relevant to the protest shall attend and testify. A minimum of 12 member clubs must be in attendance to declare a quorum.

The ruling will be by majority of those attending with the organization protesting abstaining. The protest fee will be forfeited in the event the committee rules in favor of the Commission. The penalty assessed by the Commission may, after being reviewed by the membership, be amended after a ruling has been determined.

Section 12

Players Rules & Participation

Article 1: All participants of the *INFC* must be registered on the Sportbase registration system before being allowed to participate in practices or games. Those in violation are considered illegal participants and will immediately be removed and penalties assessed to the organization and team.

Article 2: The Conference strongly promotes the active participation of all players, unless on disciplinary probation (with explanation of reason) as dictated by individual organizations and duly noted on the weigh-in roster and on the *INFC* roster. Disciplinary action will be defined as NO participation in a particular game. If a player plays one play during a game, he/she must play the full number of plays required for that particular age group. The required plays for each age group is defined below:

5th, 6th and 7th grades: all participants shall be required to play seven (7) plays in each game, including specialty team plays.

3rd and 4th grades: all participants shall be required to play twelve (12) plays in each game, including specialty team plays.

Any play including a Dead Ball Foul, Time-Out and/or Kneeling play (such as in a "Victory Formation") will not be considered or counted as a participation play.

Article 3: The team in the lead must meet all player participation requirements prior to the *INFC* mercy rule taking effect. Failure to do so will constitute a violation of *INFC* participation rules. Upon review of unusual game time circumstances the Commission may rule that circumstances prevented full participation and that the coach involved was acting in good faith.

Article 4: Any player on disciplinary action attending an *INFC* game cannot be suited-out for play. The player may wear his team jersey. Any player who refuses to participate during the game must be brought to the attention of the head official and the opposing coach. The coach must remove the helmet and shoulder pads from the player.

Article 5: *INFC* Organizations not reporting a known violation of the participation rule *will be strongly dealt with.*

Article 6: Should the Commission determine that a coach was in violation of the participation rule, that game will be ruled a forfeit and the coach will be suspended from practice and games for the next two weeks. A second violation shall be a lifetime suspension from coaching with any club member within the *INFC*.

Section 12 - B

Age/Grade requirements

Article 1: The following participation guidelines shall be as set forth below:

- To participate in the **seventh grade** league, a player must be in the seventh grade and cannot be 14 years old prior to September 1st.
- To participate in the **sixth grade** league, a player must be in the sixth grade and cannot be 13 years old prior to September 1.
- To participate in the **fifth grade** league, a player must be in the fifth grade and cannot be 12 years old prior to September 1.
- To participate in the **fourth grade** league, a player must be in the fourth grade and cannot be 11 years old prior to September 1.
- To participate in the **third grade** league, a player must be in the third grade and cannot be 10 years old prior to September 1st.
- To participate in the **second grade** league, a player must be in the second grade and cannot be 9 years old prior to September 1.
- To participate in the **first grade** league, a player must be in the first grade and cannot be 8 years old prior to September 1.

Article 2: Exceptions

- A) With approval of their association a player may play up one grade level only. A player shall not play down a grade level. *INFC* participants shall only play for one team during a scheduled season. The *INFC* player cannot play for any other conference or league team during the same season.
- B) Academic Rule: If it is determined by the *INFC* Commission that a child was promoted to a higher grade level by the school, then the child may be permitted to drop down to play for the grade level befitting his proper age. Proper proof must be submitted to the *INFC* Commissioner.

Article 3: Head coaches will maintain a file or binder with a copy of all of their player's medical release information. These must be made available to the commission and/or their appointed representative upon request.

Section 13

Team Drafts

Article 1: Maximum roster size will be thirty-four (34) players for 3rd thru 7th grade levels. Teams exceeding the maximum are required to form an additional team or teams by utilizing a drafting method approved by the Commission. At any time an organization has only one team in a grade and that team splits to two or more teams, all players will be in the draft pool except up to 4 protected players. If an organization has two or more teams in a grade and splits to three or more, existing teams may retain any or all of original players.

Article 2: A Commission member or a representative must be present during all drafts. No Commission member will supervise a draft involving that Commission member's home club.

Article 3: Upon origination (1st year) a team may recruit and protect four (4) players from the draft. Each year thereafter, the team will be allowed to recruit and protect two (2) new players.

Legal Protected players are:

- A. Participants new to the *INFC*
- B. Players who have not participated within the *INFC* for the 2 previous years.
- C. Participants who have played up from their school grade for a minimum of 2 years and are now falling back or 1 year if playing up was required due to not making the maximum weight limit.
- D. A player who sits out one year due to illness or decision not to play, will be allowed to return to that team only if the coach of that team uses one of his protects.

Article 4: A coach will not be allowed to transfer to another team unless his child is drafted to another team or the Board of Directors of that association, of which he is affiliated, allows the transfer through a vote. This transfer must then be sent in writing to the *INFC* Commissioner for final approval.

Article 5: Each organization is required to leave registration open until the Wednesday prior to the scheduled INFC Drafts, at which time each organization must inform the Commissioner how many teams will be fielded in each grade. No team drafts will be held until after the mandated registration end date.

Article 6: Draft Procedures: Teams will be drafted using a Ribbon Draft system whereas teams will pick in odd and even rounds.

Round one will be considered the even round where as the team receiving the first number will receive the first pick and progress until the team with the last number will receive the last pick in that round.

Round two will be considered an odd round where as the team receiving the Last number will receive the first pick and progress until the team with the First number receives the Last pick in that round.

Rounds will continue, even rounds being first, odd rounds being second then alternating until all players in the respective club and grade are picked.

Article 7: The Commission may order a redrafting of teams within an organization if it is determined by the Commission that an organization or coach intentionally performed an illegal procedure or performed an unethical act for the purpose of stacking a team or preventing multiple teams. If it is concluded that a redraft is necessary, the Commission will determine the manner. Action by the Commission will also be taken against the coach and/or their association. Clubs that only have two teams per grade level - if a strong player who is on a weak team requests to re-enter the draft for the purpose of allowing the stronger team the ability to draft the player, that player must have prior approval from the commissioner. Failure to comply will result in the commission redrafting both teams.

Article 8: Before leaving the draft table, coaches will be allowed to trade players but only those players that were selected during the draft. Existing players are tradable if approved by the *INFC* Representative and the drafting clubs representing Officer. Newly protected players are not tradable. Any and all player trades made after the selection of players must be approved by the *INFC* monitoring representative prior to finalization of the draft and team rosters.

Article 9: The Commission will establish the rules for drafting and will be empowered to make changes as necessary in order to maintain equality among teams. Members will be allowed to set forth more stringent drafting

rules for their organization but must be approved by the Commissioner and may be rescinded.

Article 10: A Member organization must submit to the *INFC* office prior to the first game the following: A team roster including the Coaches names, players names, player's jersey number, age, birth date and team colors. **A \$500 fine will be assessed to the member's organization should organization fail to submit the requested documents.** After which all remaining games will be forfeited until the club is in compliance.

Article 11: A player must attend school within the organization's recruiting territory (boundary) as outlined by the Commission. Unless granted a Release by the *INFC*, Pursuant to Section 14, a player is the property of the organization in whose recruiting territory the player attends school. A player must provide any information reasonably requested by the *INFC*.

Article 12: A player who departs an organization but returns the following year will be in the draft and can not be protected.

Article 13: A drafted player who quits a team after being drafted will remain the property of that team the next season unless a request is made to be put in the draft.

Article 14: Any attempt to recruit players from another *INFC* team or persuade players to leave a team and enter the draft is not allowed. A coach or association member will not be allowed to recruit a player that attends school within another organization's recruiting territory.

Article 15: In order to draft teams, member organizations must be in good standings with the *INFC*. Clubs will not be allowed to draft teams until such time as all current bills and obligation have been paid and met.

Section 14

Transfers, Releases & Waivers

Article 1:

A) A player requesting to be transferred from one *INFC* organization to another must first obtain a release in writing (using the appropriate *INFC* form) from the organization in which he is requesting the release. The signed form must then be sent to the *INFC* office to be reviewed by the

INFC Release committee. The committee may then hold a meeting with the parents of the child in question, where as a decision will be made to either grant or deny the release. The Commissioner will have the deciding vote on release issues.

- B) INFC Release Forms must be completed and turned-in no later than **August 6th** of the current year.
- C) Players that are granted transfers must be placed in the draft and may not be a protect from the draft. Players granted transfers after the draft will be assigned by the Commissioner.
- D) In territories in which that organization does not offer Mighty-Mite, Mighty-Mite transfers or releases will be given.
- E) Transfers and releases will not be given in territories which offer school football in that grade level.
- F) Authorized transfers and releases are recognized for one season only and must be renewed annually.

Article 2: A new player shall not be permitted to join an association or participate within the INFC after the second regular season game. Players moving into approved INFC territories may be granted an exception if requested early in the season and approved by the Commissioner.

Article 3: A player, having signed with a particular member organization, is the exclusive property of that organization. The player cannot be recruited by acts of persuasion by another member organization and/or its members.

Article 4: A player that resides in a territory that is shared by organizations will become the exclusive property of the organization in which the player plays his/her first season. Exceptions must be sought through the release process.

Section 15

Football Rules

Article 1: Oklahoma High School football rules will be utilized in conference play with the exceptions noted below.

Article 2: Officials:

- A. Three **certified** high school officials will be required for each regular

season game. For playoffs, however, four officials will be utilized. (The home team is responsible to pay all officials). Only those officials that are eligible to referee Oklahoma High School games will be allowed to referee *INFC* games. No coach, team official or other organizational member will be allowed to referee a conference game unless mutually agreeable to both participating teams. If a game is rescheduled and the referees are not notified, the home team may be subject to forfeiture of said game. If only two officials are present to officiate a game, the game will be played. Less than two officials will require notifying the commissioner.

B. Should the coach be incorrect on the rule and/or application of the rule a 5 yard penalty for delay of game shall be assessed to the team requesting the time-out and a time-out will be charged.

1. The head coach shall ask for a timeout. The official shall grant the time out request. The coach and the Official are then able to discuss the matter without the clock running. During this time it is acceptable to review the *INFC* rulebook. If, after the time out the coach turns out to be correct, then the call can be corrected and no time out shall be charged to the requesting team. Should the coach be incorrect on the rule and/or application of the rule – a penalty shall be assessed to the team requesting the time-out.

2. Should a coach be out of time-outs yet require discussion of a rule and/or application of that rule, he shall tell the official he is requesting a time-out to discuss a rule. The official shall grant the time-out request. Should a coach be correct on the rule and/or application of said rule the call can be corrected at this time with no consequence for calling a time-out. Should the coach be incorrect there shall be a 5 yard penalty for delay of game against the requesting team and it shall be enforced from the succeeding spot. This penalty is enforced only if the team is out of time outs.

Article 3: Practices:

A. Dates and times will be determined annually by a majority vote. For the 2021 Fall season, organized practice or conditioning will not begin until **August 2nd**. Practices will be limited to a maximum of four per week (pads or otherwise), lasting a maximum of two hours from the scheduled start time

per practice. All non-scheduled INFC games or scrimmages will be counted as practice periods with the exception of two organized scrimmages with another organization prior to the first scheduled game.

Example: Practice starts at the time parents were told, not the actual start time. Practice, including team meetings must end within the two hours allotted. Team meetings and/or the team viewing of film is considered a practice.

Mighty Mite, 3rd & 4th grade; see additional rules pertaining to practices under your appropriate sections of the rulebook.

B. Teams must have a minimum of three (3) days of outdoor conditioning without pads preceding the beginning of practice with pads.

During the first three (3) days of allowable practices, only footballs, shoes, and helmets may be used. No other protective equipment such as pads, guards, etc., and no training devices such as tackling or blocking dummies, charging sleds, or similar devices are to be used, nor shall players participate in drills that are designed in a manner as to cause contact. Training aids such as air and stand-up dummies which are non-attached, tires, ropes, boards, and any other equipment not requiring body contact, may be used.

Article 4: Camps: All camps, other than high school, college, or professional business, must have the approval of *INFC* and cannot be a team only camp. An *INFC* camp application must be turned into the *INFC* office for approval. Camps will be required to meet the following specifications:

1. Approved camp promotional material and distribution methods.
2. Individual player liability insurance or legal waiver thereof.
3. Sponsored and held by an accredited coach or professional of the sport.
4. Hosted at a facility designed for the intended use of the sport along with adequate levels of property insurance.
5. Individual player registration camp whereas participation is not predicated on team membership.

It is the intent of the INYS to neither limit nor force any off-season training on any child of the INFC. Team camp training whereas team members are required or where attendance is strongly encouraged by a coach within the INFC, with the intention to advance the abilities

of the team as one unit practicing together is expressly forbidden by the INFC. Although the INYS believes in the advancements and well-being of children through the sport of football, the INYS also believes in the advancement of children through other activities and recognizes a child's and parent's right to participate in activities outside the INFC without persecution from their coach and coaches within the INFC.

Article 5: Labor Day Holiday: Teams will not be allowed to conduct or participate in any organized practices, scrimmages, games or tournaments over the Labor Day weekend. Labor Day weekend is defined as Friday through Monday.

Article 6: Scheduling/Forfeits: Once the schedule has been distributed, any team that forfeits a scheduled game for any reason other than weather, shall immediately be assessed a fine of \$300.00. The Commission can make an exception to this rule. Games will be played on Saturday unless a conflict occurs and the Commissioner has approved an exception. The Commissioner will attempt to schedule games at a time and location that is compatible with the member's other organizational commitments. If a mutually agreed time cannot be reached, the Commissioner will issue a final ruling.

Article 7: Length of Games: Eight (8) minute quarters will be utilized for all conference play games.

1. The clock shall start for a period:
 - a. If a period begins with a free kick when the kick is touched, other than first touching by K.
 - b. If a period begins with a snap, when the ball is legally snapped.
2. The clock shall start with the ready-for-play signal for situations other than a free kick if the clock was stopped:
 - a. For an official's time-out.
 - b. Because the ball has become dead following any foul provided in either (a) or (b).
 - 1) There has been no charged time-out during the dead ball interval.
 - 2) The down is not an extension of a period or try.
 - 3) The action, which caused the down to end, did not also cause the clock to be stopped.
3. The clock shall start with the snap or when any free kick is touched, other than first touching by K, if the clock was stopped because of the

following:

- a. The ball goes out-of-bounds.
- b. A fair catch is made.
- c. A fair catch is awarded.
- d. The ball becomes dead behind the goal line.
- e. A forward pass is incomplete.
- f. A request for a charged or television/radio time-out is granted.
- g. A period ends.
- h. A team attempts to consume time illegally.
- i. The penalty for a delay of game foul is accepted.

Article 8: Mercy Rule: At which time a team reaches the 35-point spread, the score will freeze but the game will continue as normal with regular clock unless the losing team coach requests the option of a continuous running clock. No further points will be allowed on the scoreboard by either team. Normal participation rules must be followed prior to the freeze.

Article 9: Unsportsmanlike Kick: At which time the Kicking team achieves a Mercy Rule and attempts to onside kick against the Receiving team; the Kicking team coach will receive an unsportsmanlike penalty and the ball will be awarded to the Receiving team on the Kicking teams 25-yard line with a new series of downs.

Article 10: Kick-Offs: Players on the kicking team must be equally spaced across the entire field starting within 5 yards of the sideline for safety purposes.

Article 11: Scoring PAT: A successful kick will equal 2 points; a successful run or pass will equal 1 point.

Article 12: Reporting Scores: Every club/association is responsible to report the scores from all their teams each week. Those scores must be submitted to the *INFC* Office no later than Sunday at midnight. Submitting scores late or the non-reporting of a team's score will constitute an automatic fine of **\$25.00** per team.

Article 13: Half Time Procedure: (Half time is 10 minutes; 15 minutes maximum if necessary and approved) Guest cheerleaders or drill team will perform first, followed by the home cheerleaders or drill team. Homecoming activities will not be an excuse to increase the time limit. Cheerleaders, drill

teams, etc. are the responsibility of the member organization and are subject to all rules as set forth by *INFC*.

Article 14: Press Box Procedure: Rude remarks, bad behavior or biased announcing will not be permitted at an *INFC* game. If a Commission officer is in attendance at a game and determines that a violation of this rule exists and/or the clock person is not maintaining accurate precision, he/she may immediately remove that person from their duties for the remainder of the game. The Commission will then meet to determine if further action is necessary. The penalty can be up to a lifetime suspension from entering any press box during an *INFC* function. No children will be used as announcers.

Article 15: Gate Admission Fee: The conference will issue ten (10) gate passes per declared football team fielded each year to the *INFC* member organization in good standing. Allotted passes are distributed at the sole discretion of the member club. Everyone (including coaches and sponsors) is required to pay admission or furnish a current official *INFC* game pass. Exceptions are made for those players, cheerleaders, pom squad, drill team and game officials in uniform. Passes will be accepted at all *INFC* games.

Regular Season:

Adults	\$4.00
Students (6-18)	\$1.00
Seniors 65>	\$1.00
Children 5<	FREE

Playoff Finals:

Adults	\$5.00
Students (6-18)	\$2.00
Seniors 65>	\$2.00
Children 5<	FREE

Any coach or person (s) caught in an attempt to gain entry with a false or reproduced *INFC* pass, gain entry without their pass and/or refuse to pay gate admission, or caught attempting to "hand-off" an *INFC* pass to another individual will be ejected and subject to having their pass revoked, further suspension, and/or a fine up to \$100.00.

Article 16: Chain Crews: The **visiting team** is responsible for providing a chain crew for each game unless an exception is granted by the Commissioner.

Article 17: Radios: The use of two-way radios will be permitted by coaches in the press box, on the field of play/sidelines (between the 25 yard

lines). Players are not allowed to use radios or any other electronic equipment.

Article 18: Video Cameras: The filming of games by parents or coaches will be allowed at any *INFC* sanctioned event.

Article 19: Blocking & the Free Blocking Zone: The free-blocking zone is a rectangular area extending laterally 4 yards either side of the spot of the snap and 3 yards behind each line of scrimmage. A player is in the free blocking zone when any part of his body is in the zone at the snap.

Blocking in the back is permitted in the free blocking zone when the following conditions are met:

- A. By offensive lineman who are on the line of scrimmage and in the zone at the snap.
- B. Against defensive players who are in the zone at the snap.
- C. The contact is in the zone.

The free blocking zone disintegrates and the exception for the offensive lineman to block in the back is not to continue after the ball has left the zone.

An offensive or defensive player on the field of play including inside the free blocking zone shall not initiate a clip or block below the waist of an opposing player.

Chop blocks take two blockers to execute and are illegal everywhere on the field, including in the free blocking zone. A chop block is a combination block by two or more teammates against an opponent other than the runner, with or without delay, where one of the blocks is low (at the knee or below) and one of the blocks is high (above the knee).

Section 16 Weight Limits

Article 1-A: The following weight limits will be utilized for all *INFC* games.

Grade	Max Offensive Back	One Striper	Two Striper	Maximum Weight
1st	60.00	60.01 to 80.00	over 80.00	105.00
2nd	70.00	70.01 to 90.00	over 90.00	115.00
3rd	80.00	80.01 to 100.00	over 100.00	130.00
4th	90.00	90.01 to 115.00	over 115.00	150.00
5th	110.00	110.01 to 135.00	over 135.00	170.00
6th	130.00	130.01 to 160.00	over 160.00	none
7th	150.00	over 150.00	none	none

Article 1-B: A Player exceeding the maximum weight limit for their particular grade level will be required to play up into the next grade level.

A player exceeding the max weight limit after having moved up a grade level will be allowed to participate in that grade after receiving permission from the *INFC* Commissioner. A special decal will be issued to be worn on the helmet along with three (3) letters signifying the approval & exception.

Article 2: Striped Players

Players within the specified weight ranges of one or two stripes will have their helmets marked accordingly:

- One Striper - A neon green stripe placed vertically at the center rear base of the helmet.
- Two Striper - A neon green "x" placed at the center rear base of the helmet.

Neon stripes are available from the *INFC* office and your club.

All Weigh-ins will adhere to the *INFC* weigh in procedure. Players exceeding the maximum weight in the 3rd, 4th and 5th grades prior to the start of each

game will not be allowed to play. Illegal participation by a player will result in a fifteen-yard penalty. The Commissioner will impose further penalties to the coach and/ or team if it is determined that the player/players were used illegally in order to change the outcome of the game. Weight limits are set by *INFC* for safety and must be strictly adhered. **No exceptions will be allowed or tolerated.**

A. One Stripe Player:

Offense

1. May play end but is not an eligible receiver and cannot advance the ball in a designed play but may advance the ball after the recovery of a DEFENSIVELY CAUSED fumble.
2. Not allowed to line up in the backfield except to place kick, for extra points and/or field goals. Must be a declared kick, a fumble or fake will be declared a dead ball. If the kick is blocked and remains behind the line of scrimmage, a one (1) striped player may advance the ball.
3. May place kick but cannot punt.

Defense

1. May play any position.
2. Not eligible to return a kick off or punt.
3. Allowed to return an interception or fumble.

B. Two Strip Player:

1. Cannot have more than three (3) two stripe players on the field of play at any one time.
2. Can only be a lineman in a down position, 3 or 4 point stance.
3. Cannot participate on the kick-off or kick-return team.

Offense

1. Must play on the interior offensive line and may never be in a position to be eligible for a pass. **Note:** On an unbalanced line, the tackle becomes an end if uncovered making him illegal.
2. Will be allowed in the backfield to kick extra points or field goals only. Kick must be a declared. A fumble or fake will be declared a dead ball. If the kick is blocked and remains behind the line of scrimmage, a Two Striped player may advance the ball.

3. Two stripe players cannot advance the ball in a designed play but may advance after the recovery of a DEFENSIVELY CAUSED fumble.

Defense

1. Must play on the defensive line and cannot line up wider than head-up with the offensive end's normal position whether the end is lined up on that side or not.
2. Will be allowed to return a fumble or pass interception.

Article 3: Weight Limits/Scales

Weight limits are imposed by the INFC for reasons of safety. Should anyone be caught tampering with scales prior to weigh-in and then found to be guilty of such tampering, that person shall be removed from the field immediately and shall be banned from all INFC activities for the remaining season. Further actions may be imposed by the INFC Commission.

Article 4: Weigh-In Procedure

A. Teams will meet 30 minutes prior to scheduled game start time for weigh-in. Players participating in the game must have their helmet & jersey they will wear for that game with them at weigh-in. Players may weight in minimum clothing wearing only gym shorts.

If at any time a coach is not complying, contact the commissioner or commission officer immediately. The commissioner phone number is 918.850.7162.

Penalty: a team not present at the weigh in area 30 minutes prior to the scheduled start of the game will be penalized by the suspension of the head coach for the first half of the ball game. The coach must sit in the stand and will not be allowed to coach. The coach will not be allowed to use radios or make contact with the team or coaches by any means.

B. The home team must furnish and use a balance type hospital scale or commercial type digital scale prior to each team weighing-in. Appropriate fingernail length shall be checked at weigh-in.

1. Coaches must be shown a zero balance.
2. If scales are broken or unavailable for weigh-in, a Commission Officer must be contacted immediately. The Commission Officer will

determine the process depending on the situation.

C. Coaches shall bring (3) three digitally typed (& not hand written) official INFC rosters to the weigh in (distributed to the press box, opposing coach, and weigh in administer). Hand written quarter assignments & game day decisions are exceptions to the digital format.

1. Players must be organized in numerical order on the roster. Notations as to players not in attendance and/or who are on disciplinary action shall be listed on the roster through- out the entire season. The Commission can ask for rosters at any time and they **MUST** be made available.

2. Coaches who fail to submit a roster to the opposing coach at the time of weigh-in will set out the first half of that game and will not be allowed to coach or communicate with the coaches or players of their team under any circumstance outside of individual player health or safety.

3. The maximum weight will be set at each player's particular weight class. The player weighing must be at equal or less than specified weight limit. If the bar touches the top and stays at the top, the player will be required to play up to the next weight class. **Coaches (opposing or otherwise) are not allowed to make exceptions for any players.**

Penalty: If an exception is made, the coach making the exception will be suspended and assessed a \$50 fine.

4. A player will be allowed to weigh-in two (2) times with the second to be done within five minutes of the first weigh-in.

5. Players late for the weigh-in (not in attendance by the completion of both teams weighing in) must and will be weighed in prior to the start of the game. Late players will be penalized by not being allowed in the game until the start of the second quarter.

Players not in attendance five minutes prior to the scheduled start of the game will not be allowed to play until the start of the third quarter and must be weighed in during halftime or before.

6. A player who is discovered to have been allowed to participate in a game without being weighed will not be allowed to participate in the next scheduled game. The Commission will suspend the coach responsible.

Every player must step on the scale, no exceptions shall be granted.

7. A team found guilty by the INFC Commission of breaking any of the rules, as

set forth in the adopted weigh-in procedures will be subject to the forfeiture of the game. The coach/coaches shall also be subject to additional suspensions, fines and/or penalties.

Section 17

AA League

Article 1: The "AA" league will consist of 4th, 5th, and 6th grade teams considering that grade can fill a division. Teams qualifying to play in the AA league must meet one of the following requirements:

1. Teams must qualify as being in an 1A, 2A, or 3A club as listed by the Oklahoma Secondary School Activities Association (OSSAA).
2. Teams classified as in an A division club with a poor winning record the previous year or newly formed teams the commission determines will have difficulty performing in the A league. Qualifying teams will be determined annually by a number system adopted by the INFC.
3. Member clubs classified as 1A, 2A, or 3A clubs shall advance to play in the A division if the club grants an exception. All 4A, 5A, & 6A club teams must be approved by the INFC Commission before play is allowed in the AA league.
4. A team allowed to transfer from the A to the AA league must return to the A league the following year if first or second place in the team's division is achieved.
5. Teams competing in the AA Championship game shall be prohibited from participating in the AA league the following season.

Section 18

Post-Season

Article 1: General Playoff Info

Playoffs & Post-Season Tournament (PST) games will be scheduled following the end of the regular season. Play-Off and PST game rules are subject to change on an annual basis.

Article 2: Marginal Points

Marginal Points shall be calculated for each divisional game played throughout the regular season. Marginal points are tallied up to +/- eight points per game & shall be based on margin of victory. No team shall add or subtract more than eight points per game.

- A. For overtime games, the maximum number of marginal points shall be calculated at + one point for the winner.
- B. If two teams are tied (on marginal points), the advancer shall be the team that defeated the other during the regular season.
 - 1. If three teams are tied (on marginal points), the advancer shall be determined by coin toss at a time and place determined by the Commissioner.
 - 2. Remaining playoff spots for tied teams, which lose the coin toss, shall be determined by which team defeated the other during the regular season play.

Play-Offs

Article 3: Play-Offs Grades consisting of three or more divisions shall advance top three teams in each division. Grades consisting of two divisions shall advance the top four teams in each division. Grades having only one division shall advance the top five teams in the division.

Article 4: Division Tie Breakers If two teams have equal records at the end of the regular season play, the team that won over the other will be considered to have the higher league standing.

- A. In the event three or more teams are tied with identical records and no winner can be determined, the advancing team shall be determined by totaling the margin of points for each tied team in all Divisional games (or division games if two or more divisions). The advancing team shall be the team with the greatest number of marginal points.
- B. Any remaining playoff spots for the remaining tied teams shall be determined by the winner over the other during the regular season as above.

Article 5: Championship The finals of the championship playoff games will be played on a field to be determined by the Commission.

- A. The proceeds from the championship games of the A Division, AA Division and the Tournaments, after deducting costs and expenses, shall be split with the Conference receiving .50 percent and the host association receiving .50 percent of the net profits.

Section 19

Special Rules Governing 3rd & 4th Grade Tackle Football

Article 1: Participation: Every player must play a minimum of twelve (12) plays per game. Specialty team plays are included.

Article 2: Center Protected: In the 3rd and 4th grade level, the defense will not be allowed to make contact with the center on a deep snap, including shotgun offense, until such time that the ball makes contact with offensive back or when the ball makes contact with the ground not direct hand to hand contact.

Article 3: Limited On Field Coaching: In the 3rd and 4th grade level, one coach will be allowed on the field on offense and defense the first two regular season games. Any team with a scheduled bye the first or second week will be allowed to have one coach on the field the third game. A coach who is declared by the official as interfering with the play in progress will be banned from both offense and defense for the remainder of the game plus the offending coach's team will be penalized 15 yards. In the event a coach interferes with the offense causing what is determined by the official as a probable score, the score will be awarded plus a fifteen (15) yard penalty assessment on the kick off. The offending coach will be dismissed for the remainder of the game.

Article 4: 20/20 Punt: Teams may elect to attempt the punt. However, they may also opt to declare the punt and the ball will advance 20 yards down field. The Ball will never be placed inside the opposing team's 20 yard line.

Article 5: Practices: 3rd and 4th grade teams will be allowed four (4) practices per week for the first three weeks of practice. Practices will then be limited to three (3) per week. No one practice will exceed two (2) hours in length.

3rd – 7th grade Post-Season Tournament (PST)

1. The INFC Commissioner will be Tournament Director and will make the final ruling on any disputes. Unacceptable behavior, unsportsmanlike conduct, or violation of rules will not be tolerated. The penalties assessed for infraction of the rules will be the suspension of coaches, parents, or players, forfeiture of game(s), the team elimination from the tournament, or any action deemed appropriate by majority vote of the Commission.
2. All INFC Bylaw rules will be in effect including INFC regular overtime rules and INFC regular gate admission policy (exceptions to gate policy administered for Championship games).
3. Tournament format will be double elimination with single elimination in the semi-finals. (NO IF GAMES)
 - a. Games are scheduled to start on the hour.
 - b. 20 minute running clock per half with 5-minute half-time intermission. During the final minute of the game, the clock will run in accordance with OSSAA High School rules. This rule is to allow a team to stop the clock on incomplete passes, running out of bounds, etc. to prevent teams from stalling in the final minute of play. Captain's choice will be secured before leaving the field at half.
 - c. Each team will be allowed one (1) time out per half. No carry overs to the 2nd half. The Official, at his discretion, can stop the clock and issue a delay of game penalty if, in his opinion, a team is intentionally delaying the game. The clock will stop with injuries and time outs (clock does not stop after a touchdown).
 - d. Tournament finals will be full game with a mandatory weigh-in.
 - e. Suspension of play due to inclement weather may result in moving each game's starting time or complete rescheduling.
 - f. Forfeit fee of \$100.00 per game will be assessed to the team.
4. Standard kick off and receiving procedures will be in effect.
5. Five - play minimum participation rule for all grades for each game will be in effect.
 - a. Tournament finals will adhere to regular season participation rules as dictated by grade.

6. PAT procedure will be one point scored for a successful run or pass; two points for a successful field goal.
7. Each team may provide their own football with at least one backup ball, meeting all specs. Team attendants, ball boys or coaches will be responsible for relaying their ball to the officials each time their team goes on offense or when, during their series of downs, the ball in play can not be quickly retrieved or is wet and a backup ball is required to speed up the game.
8. There will be a team weigh-in before each game. However, a team playing a back-to-back game will not be required to weigh for the second game if the field director has secured an official weigh-in roster from the first game.
9. The home team will be the team identified on the top of the bracket and the visiting team will be responsible for providing the chain crew for each game.
10. Competing teams will warm up outside the playing field until the previous game is completed. They may take the field and continue warm-ups until game time. After a warning by the Official, a team must take the field immediately ready for play or face forfeiture. Captains must be at their sideline for the coin toss two minutes before game time.
11. First and second place teams will be awarded trophies. Host sights and dates will be announced after all entries are secured.
12. Teams will not be allowed to add/pick up players during the Post Season Tournament.

Section 20

Rules Governing Overtime (Tiebreaker)

Article 1: Overtime (Tiebreaker for INFC Play Off Games)

- a. National Federation High School Rules (NFHS/Oklahoma High School Rules) will apply.

Article 2: Overtime (Tiebreaker for INFC Regular Season Games)

- a. After the coin toss options, play will start at the defensive team's 25-yard line.
- b. Each team will have one series of downs, 1st and goal, starting at the 25-yard line.
- c. Teams cannot make a 1st down or be awarded an automatic 1st down.
- d. If a defensive team penalty is accepted, the down will be replayed.
- e. If an offensive team penalty is accepted, the down will be replayed unless the penalty carries a loss of down.
- f. Whichever team has the highest score or the most penetration distance after 4 downs and maintains possession for all 4 downs, wins the game.
- g. If both teams have lost yardage after 4 downs, or have lost possession, or have the same score or penetration, the overtime will be replayed.
- h. Defensive pass interference carries a 15-yard penalty if accepted plus the down is replayed.
- i. The offense must maintain possession. If the defense gains possession of the ball during play, the ball becomes dead and the team in original possession will be recorded with zero yards gained.
- j. One point will be awarded for the score in an OT victory.

Section 21

Rule Changes

Article 1: By-law and rule changes may be amended, adopted, or repealed at any regular meeting by a majority vote of the membership. All rule change suggestions should be submitted on or before the January annual meeting in writing for review of the bylaws committee.

**ADDITIONAL INFC RULES PERTAINING TO
MIGHTY MITE FOOTBALL**

MIGHTY MITE / 1st & 2nd GRADES

Section 1

Purpose

The purpose of the INFC Mighty Mite Football Program is to educate football players on the fundamentals of football in a semi-competitive atmosphere.

Section 2

General Information

Article 1: The Mighty Mite program will consist of first and second grade teams playing 8-man football with mandatory half game participation.

Article 2: Organizations may only recruit players from their territory. There may be an exception granted under the classification of exceptional circumstances as determined by the INFC Commission.

Article 3: **INFC Mighty Mite Football Program** will use equivalent of pee wee footballs (leather, composite leather).

Section 3

Coaches and Parents Rules

Article 1: **Every** coach will be certified by USA Football. It will be the responsibility of the association to ensure their coaches are certified.

Article 2: Each association will be responsible for the conduct of all their coaches. Coaches are responsible for the conduct of their parents.

Article 3: **Every** coach **must** attend an INFC coach's orientation meeting. Failure to comply will result in a \$200.00 team fine. No games will be played until such fine is paid.

Article 4: There will only be three practices allowed per week. Each practice can only be a maximum of 1-½ hours long from the scheduled start time. This includes warm up, drills, training, and cool down, team meetings (everything).

Article 5: Only one coach from each team will be allowed on the field during game play.

Article 6: There will be no coaching while play is in progress. The coach must be a minimum of 15 yards back from the line of scrimmage; there will be no communication with a player once the line is set and cadence begins. Officials will grant only one warning. If there is a second offense, the official will eject that coach from the playing field to the sidelines.

Article 7: If a coach on the field while addressing an official precipitates a delay of the game, that team will be charged a **time out**.

Section 4

Drafts

Article 1: The Mighty Mites will be classed into two divisions. One being second grade division, consisting of teams of all second graders or a combination of first and second graders. To participate in second grade division, the child must be in the first or second grade and cannot turn 9 years old prior to September 1.

The first grade division will consist of Kindergarten (at the option of each member organization) and first graders. The participants in the first grade division, the child must be in Kindergarten or first grade and cannot turn 8 years old prior to September 1.

Article 2: An INFC Commissioned officer or an appointed committee member of the INFC Mighty Mite Football Program must supervise all drafts.

Article 3: Protects – For new-formed teams there are four (4) protects. For existing teams there are two (2) protects.

Article 4: Within INFC Mighty Mite Football Program it will be the parent or coaches request to remove a child from a team and place him/her into the draft. Otherwise, the player remains with the previous Mighty Mite team.

Article 5: When a player or team advances to the third grade level all INFC new team rules apply.

Section 5

Player's Participation Rules

Article 1: Rosters

- A. A team must not carry more than **15** players.

The Commissioner may grant a team 16 players should he deem it absolutely necessary. However, two (2) quarterbacks must be utilized during all INFC games.

Article 2: Player Participation

A. There will be no playing up of a 2nd grade player unless the following criteria is met:

1. Age of the player does not allow the child to participate in the second grade.
 2. Maximum weight of the player does not allow the child to participate in the second grade.
 3. The player has played no less than two years of Mighty Mite football.
 4. The player has met one of the preceding criteria and has club approval.
- B. Players must be residing within their boundaries as outlined by *INFC* unless exception is given by the Commission.
- C. Each player must play **two (2) quarters of uninterrupted play**, playing at least 1 quarter in each half, both offense and defense. This must be shown on the roster and given to the opposing coach at weigh-in.

There will be no substitutions within a quarter other than for injury.

Once injured player recovers, player must immediately re-enter the game to fulfill the quarter started. If player is late for weigh-in then that player will not play until second half and only be required to play one quarter.

- D. PENALTY- The head coach proven to be in violation of the participation rule will be assessed a severe penalty (suspension or season removal) issued by *INFC*.

Article 3: Weight Limits

First Grade

- A. Maximum playing weight is 105.00 pounds.
- B. Maximum playing weight for advancing the ball is 60.00 pounds.
- C. Striper weight limits as follows:
 - 1. One striper: 60.01 to 80.00 pounds.
 - 2. Two striper: 80.01 to a maximum of 105.00 pounds.

Second Grade

- A. Maximum playing weight is 115.00 pounds.
- B. Maximum playing weight for advancing the ball is 70.00 pounds.
- C. Striper weight limits as follows:
 - 1. One striper: 70.01 to 90.00 pounds.
 - 2. Two striper: 90.01 to a maximum of 115.00 pounds

Both First & Second Grades

- A. **One Striper:** A striper is not allowed to be in the offensive backfield. On Offense a striper may advance the ball only after the recovery of a DEFENSIVELY CAUSED fumble. On defense a one striper can play all positions.
- B. **Two Striper:** A two striper must be a lineman in a down position three or four point stance; offense or defense. On Offense a striper may advance the ball only after the recovery of a DEFENSIVELY CAUSED fumble. On defense a one or two-stripped player will be allowed to return an interception or fumble.
- C. Players weighting within the specified weight ranges of striped players must have their helmets marked within INFC guidelines. Guidelines are as follows:
 - * One Striper – One neon green stripe shall be placed at the rear of the helmet, be centered so it is visible behind the helmet and run vertical up the helmet.
 - * Two Striper – One neon green "X" shall be placed at the rear of the helmet and be centered so it is visible behind the helmet.

Neon stripes are available from the conference office and from your local club.

- D. All weigh-ins must follow the official INFC weigh in procedures.

No exceptions will be allowed or tolerated.

Article 4: Weigh-In Procedure

Refer to Section 16 Article 4, and Article 4(3)

At weigh-in, each team must furnish three official INFC Mighty Mite player participation rosters (press box, opposing coach, and weigh-in administrator) for the game. This roster must be the official INFC Mighty Mite roster.

The game will not proceed without each team having the opposing team's player participation roster showing name and the quarter in each half each player is in the game.

PENALTY: A team not present at the weigh-in area with proper documentation 30 minutes prior to the scheduled start of the game will be penalized by the suspension of the head coach for the first half of the ball game. He must sit in the stand and will not be allowed to coach. He will not be allowed to use radios or make contact with the team or a coach by any means what so ever. Violation of this rule will be removal of the coach for the remaining football season.

Section 6 Game Rules

Article 1: Oklahoma High School Rules will be utilized in this league with the exception of the INFC Rules contained within.

- A. **Field Size** – The field width will be reduced to no less than 35 yards, no more than 40 yards.

Example: Field width will be set up from near sideline to the far hash marks.

- B. **Game Time** – 8 minute quarters will be utilized for all Mighty Mite League play.
1. This is a continuous running clock, stopping only for Touchdowns, Time Outs, Injury, and Extra Points.
 2. A team is allowed **35** seconds between each play. Time starts at the placement of the ball by the official.
 3. Two (2) minute warning will be given at the end of the 4th quarter and regular regulation play will be in effect during this time (*no running clock*).

4. Each team is allowed two (2) time outs per half.
- C. **Punts - the 20/20 rule**
The punt team must notify the official of their intent to punt. The official will at that time place the ball 20 yards downfield. At no time shall the ball be placed inside the receiving team's 20 yard line.
- D. **Fumbles** – A fumble **can be recovered** and advanced, utilizing the ball advancement rules.
- E. **Ball Placement** – The ball is to be placed on the 40-yard line.
1. At the start of the game.
2. After each touchdown, extra point.
3. At the beginning of the second half.
- F. **Scoring** – The score will be kept on the board to ensure the mercy rule is obeyed.

Points –

- A. **Six** points for a touchdown.
B. **One** point for an extra point by running.
C. **Two** points for an extra point by kicking.
D. **Three** points for a field goal.
- G. **Mercy Rule** – At the time a team reaches a 28 point spread, the score will freeze and *INFC* mercy rule procedures apply.
- H. **Tournaments** - *INFC* will determine the format for preseason and/or post season activities and tournaments. In the event that *INFC* chooses a post-season tournament, tournament seeding will be determined by a blind draw system.
- I. **Overtime** – During regular season no overtime will be played.

CONDUCT

Article 1: Any assault, verbal abuse, profanity, or display of UN-sportsmanlike conduct by a coach, parent, participant, club official, or guest at any **INFC function** will not be tolerated. Intentionally running up the score will be classified as UN-sportsmanlike conduct. Violations will be dealt with accordingly.

Article 2: Alcoholic beverages, illegal drugs and/or the consumption of alcoholic beverages and/or illegal drugs will not be tolerated by anyone at an *INFC* sanctioned function.

Article 3: The penalty for any infraction will be one or more of the following:

- Fine up to \$500.00.
- Suspension from a game or games.
- Lifetime suspension from any **INFC Football Event, or Game.**
- Probation.
- An action deemed appropriate by the INFC Commission.

Section 7

MIGHTY MITE DEFENSE

All 1st & 2nd grade teams must run the same defense as designed until the snap of the ball.

1. The Safety must line up no closer than 5 yards from the line of scrimmage and can move laterally.
2. Cornerbacks must be no closer than 3 yards from an Offensive End and must be set and positioned 3 yards back from the line of scrimmage.
3. Must have 3 or 4 Defensive lineman.
 - A. Defensive Guards must line head up with the Offensive Guard, not in the gaps ,and must begin play in a down position.
 - B. Defensive Ends must line head up or on the outside shoulder of the Offensive End.
 - C. A two striper must play on the line in a down position.
4. All linemen must line up in a down position.
5. May have one or two Linebackers that must line up 3 yards back from the line of scrimmage, can move laterally between the center and the end. If there are two linebackers they must line up on opposite sides of the ball.
6. No more than (2) two stripers are allowed on the field from each team at one time.
7. The Offensive Center is protected; a defensive player must go to the left or right of the Center.
8. The defense is frozen and no adjustments are allowed once the offensive line is set.
9. Inside the 5 yard line the defense is allowed to move the Linebacker(s) and Corner Backs to within one yard from the line of scrimmage. The middle linebacker can line up over the Center but is not allowed head on contact with the Center. The Safety can move to within 3 yards from the line of scrimmage.
10. **The Center is always protected.**

Defense — 1 Linebacker

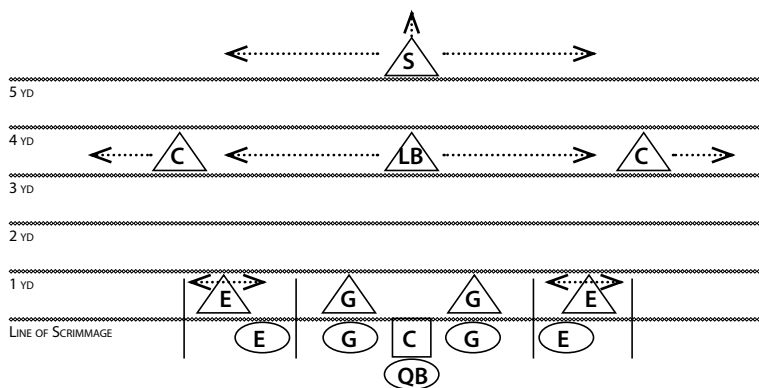

Defense — 2 Linebackers; 1 Guard (either Guard can be utilized)

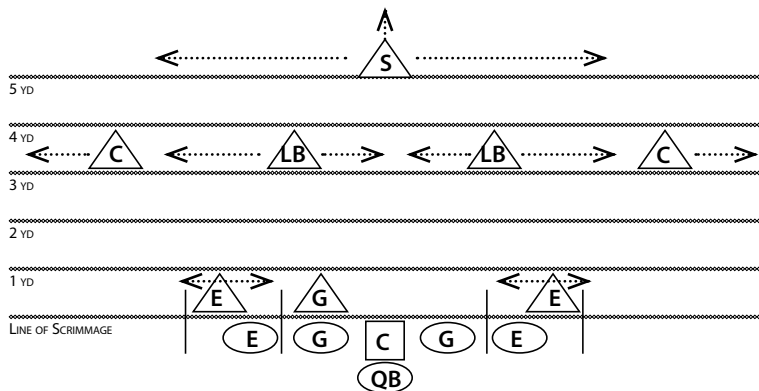

Defense — 2 Linebackers; 1 End (either End can be utilized)

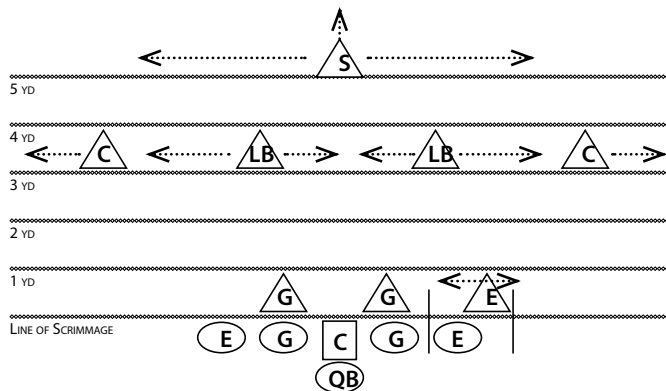

Defense — Inside 5 yard line

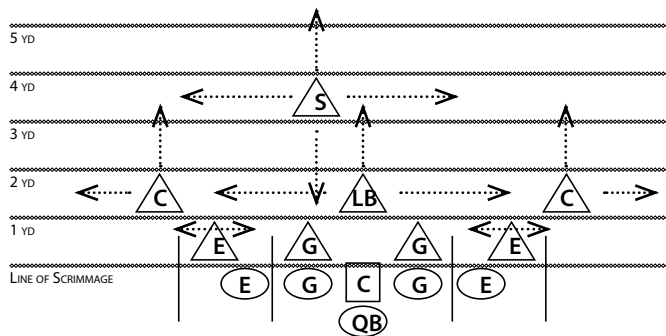

Section 8

MIGHTY MITE OFFENSE

All teams must run the same offense as designed by the diagrams above until the snap of the ball. **NO EXCEPTIONS.**

1. Must have five players on the line of scrimmage, all in the down position.
2. End position can be two striper as long as they are in a down position.
3. Ends cannot split out, but they can go out for a pass after the snap, following the ball advancement rules. i.e. No Stripers.
4. Maximum splits on the line are fingertip to fingertip of the lineman.
5. Quarterback can start in the shotgun formation directly behind the center no farther than two yards back from the ball.
6. Must have two backs in the backfield that line up at least two yards deep from the line of scrimmage. (Not counting the quarterback).
7. Backs must line up behind the guards in the split formation.
8. Backs must line up behind the center in the I formation, no offset I formations.
9. No players shall be in motion before the snap of the ball.
10. Unless approved by the Commissioner and only for reasons of team size and player participation; no more than (2) two stripe players are allowed on the field from each team at one time. When approved and only when facing a team granted approval by the commissioner, team A can match the total number of two stripe players on the field as team B.
11. A team is allowed a maximum of 35 seconds from the time the ball is spotted by the Official until the snap.

Split Back Formation

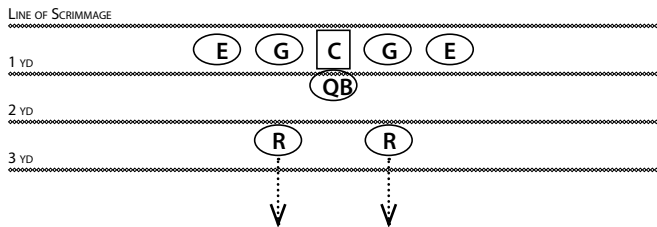

I - Formation

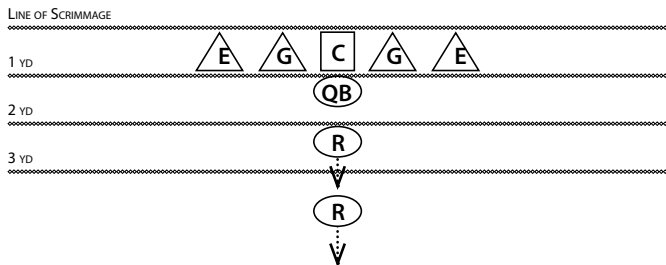

Shotgun / I - Formation

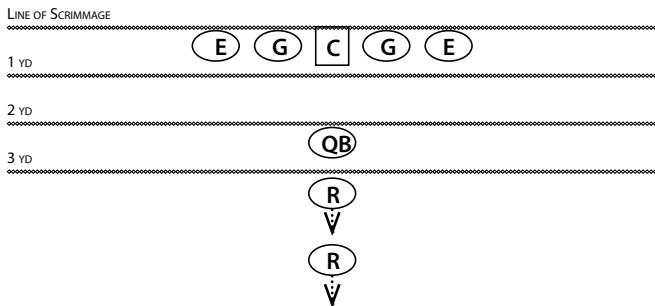

Shotgun / Split Back Formation

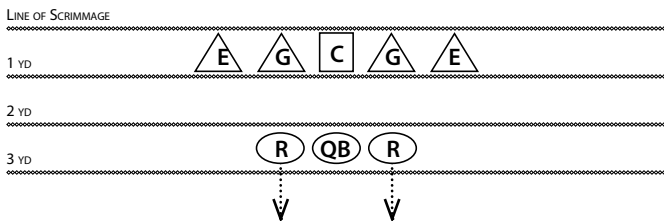

**ADDITIONAL RULES
PERTAINING TO CHEERLEADING & SPIRIT**

CHEERLEADING & SPIRIT

Section 1

PURPOSE

Article 1: The purpose for all INFC Cheerleading & Spirit squads will be to promote and uphold team spirit for those we encounter, to develop good sportsmanship by example, to support good relations in the community and between teams and squads during events. The organizational goal is to work in harmony with the team management, administration, and other athletic teams and sporting organizations.

Section 2

CHEERLEADING & SPIRIT COUNCIL

Article 1: INFC Cheerleading & Spirit Council has been formed to make recommendations and to assist in establishing guidelines for Cheerleading & Spirit programs for all INFC Member Organizations. The Cheer & Spirit Council shall be made up of a representative from each INFC Member Organization. The President of INFC Cheer Council shall be known as the INFC Director of Cheer & Spirit and will also serve on the INFC Commission. This will be an elected position to serve one year.

Article 2: Meetings shall be held at the request of the Commissioner, Director of Cheer & Spirit, or at the request of any four-member organizations within fourteen (14) days of such request. These meetings shall be limited to the individual member organization's representative, coaches and member organization officers; however, each organization will be limited to three active participants during any meeting. The Commissioner can grant exceptions. Persons other than those listed above wishing to attend a Council meeting and/or address the membership must first have approval of a Commission Officer.

Article 3: Each organization must be notified at least 72 hours in advance of any meeting and be given the purpose of the meeting. No conference business can be conducted unless this condition is satisfied.

Article 4: INFC Cheerleading & Spirit Council will hold a General Conference

Meeting as early as January but no later than a week before the tackle membership meeting is held. The purpose of this meeting will be to review previous year's issues, gather suggestions for the next season, and the election of officer.

Article 5: One vote per club. No proxy votes will be accepted.

Article 6: Members may only vote on issues pertaining to the grade levels represented within their club.

Article 7: Upon completion of the voting process, the INFC Director of Cheer-leading & Spirit will submit the results of the vote to the INFC Commission for final consideration and approval.

Section 3

ELECTION OF DIRECTOR OF CHEER & SPIRIT

Article 1: The INFC Director of Cheer & Spirit shall be appointed by the INFC Commission.

Article 2: INFC Director of Cheer & Spirit must have been an active member of INFC the previous year with 75% attendance.

Article 3: He/She shall be elected to serve a one year term from time of election.

Section 4

MEMBERSHIP

Article 1: To be a member cheer club within the Indian Nations Football Conference, the cheer or spirit club must enter the league through the tackle club member of the INFC league.

Article 2: A cheer or spirit club that is a member of the INFC league may not participate in another conference or league. Each cheer or spirit club admitted into the INFC must detail in writing the structure of their organization; the officers of their organization, position held, their telephone number and email address. This information must be provided to the INFC Director of Cheer &

Spirit and the INFC office upon admittance into the league and annually at the beginning of each season.

Article 3: A Cheerleading & Spirit organization and/or its individual teams not in compliance with the INFC rules may be suspended by the Commissioner and the Commission or removed by majority vote of the INFC member organizations.

Section 5

RULES AND REGULATIONS

Article 1: The rules governing the tackle and Cheerleading & Spirit programs as well as member's rules and regulations are set by the INFC Commission Officers. The INFC Commission Officers will acknowledge and hold firm any and all rules and policies.

Article 2: The Cheerleading & Spirit rules are an extension of the INFC football rules. All rules that are suitable or would apply shall be adhered to by all cheer or spirit clubs cheering for INFC clubs/teams. These rules and regulations will be applied throughout the regular tackle football season and Cheerleading & Spirit competition season.

Article 3: The INFC Commissioner is empowered with the authority to limit, restrict, or make changes as deemed necessary.

Article 4: Cheer or spirit organizations must abide by all rules as set forth by INFC. Officers, coaches, and parents will be held accountable for any rule violations.

Article 5: If a Cheerleading or Spirit organization is operated separately from the tackle football program, the cheer or spirit club will be liable for all penalties assessed by the INFC Commission Officers/INFC Cheer Council.

Section 6

RULE VIOLATIONS

Article 1: Violations of league rules will be acted on and penalties assessed by the INFC Commissioner and reviewed by the Commission, which at that time can, by majority vote, overrule or reinforce the Commissioner and his actions. The penalty or penalties assessed against an organization, coach, parent or

cheerleader/player can be one or more of the following:

- Fine
- Suspension of coaches or individuals within an organization
- Probation
- Any action deemed appropriate by majority vote of the INFC Commission

Article 2: Assaults, verbal abuse, profanity or display of poor sportsmanship by a coach, parent, participant, club official or guest at an INFC function will not be tolerated. Illegal drugs, alcoholic beverages or the consumption of them will not be permitted during any INFC function. Penalties will be dealt accordingly.

Article 3: A coach or cheerleader/player having been ejected from a game will automatically be suspended for the next game. The coach or cheerleader/player will be allowed to practice but will not be allowed to participate except as a spectator in the stands. The INFC Commissioner, upon review, is authorized to make an exception if it is determined that such exception be deemed appropriate. A coach or cheerleader/player may also receive a harsher penalty if deemed warranted by the INFC Commissioner.

Article 4: A club must report in a timely manner to the Commission office involving any rule violation of the INFC Bylaws.

Section 7

CERTIFICATIONS AND CLINICS

Article 1: Each head coach and all members of each coaching staff will be ASEP certified in Cheerleading & Spirit and will show proof when requested by a Commission officer. The President of each association will turn in to the INFC office a list of all coaches involved in their program along with a copy of their ASEP card prior to the first regular season game.

Article 2: Exception to ASEP certification would be:

- School Certified Coaches

Article 3: All Coaches on the sideline must wear a copy of their certification and their INFC pass on a lanyard around their neck.

Article 4: The head coach is responsible for their sideline. If a sideline coach is not wearing the certification, the coach in question will be removed from the sideline and prohibited from coaching. The head coach and the coach in violation will both be subject to suspension from practices and/or games.

Article 5: The number of non-player personnel on each cheer squad's sideline shall not exceed a total of three (3). These three (3) include the coach and two assistant coaches.

Article 6: One coach from each team must attend the mandatory coaches meeting. Failure to comply will result in a \$200.00 team fine. All games will be forfeited until such fine is paid to INFC. Persons caught in an attempt to falsify attendance for another coach will be suspended for the season.

Section 8

GENERAL COACHES RULES

Article 1: A child's health and well-being will be the first objective for any coach.

Article 2: For safety and liability purposes, INFC requires a coach to be 18 years of age or older. (A coach refers to the adult responsible for the squad.)

Article 3: A coach will adhere to all rules and regulations as set forth by their organization and the INFC Conference.

Article 4: An ASEP Certified adult must be present at all practices, games, and competitions.

Article 5: A coach will not be permitted to use profanity, abusive language, alcohol, tobacco of any kind, or conduct herself/himself in a manner that

could be deemed offensive. This rule will apply to all practices, games, or function involving cheer squad while representing your club and INFC.

Article 6: If a problem or situation arises with another INFC Organization, the INFC Director of Cheerleading & Spirit and/or INFC Commissioner must be notified immediately.

Article 7: If a problem or situation arises within the Cheerleading & Spirit squad, the coach is expected to resolve any grievance. If a solution is not reached, the coaches are expected to direct the grievance to their Organization. If the grievance is still not resolved, then the INFC Director of Cheerleading & Spirit shall then be notified. Finally the INFC Commissioner shall be notified of the grievance if not resolved after following the above channels. This only applies to INFC rule violations.

Article 8: No degrading, negative cheer/chants towards another squad will be performed.

Article 9: Each cheer club will be responsible for the conduct of all their coaches. Coaches are responsible for the conduct of their parents.

Section 9

PARTICIPATION RULES

Article 1: INFC Cheer Council prohibits Cheerleading & Spirit tryouts of any type. Every participant who completes registration requirements with an organization shall be allowed to participate on a cheer squad. This rule applies to both recreational as well as competitive squads.

Article 2: Each organization is required to define their Cheerleading & Spirit registration dates by advertising the beginning and ending dates. Every participant must be accepted until the ending date for registration. It is strongly recommended the advertisement be kept for verification should the need arise.

Article 3: Violation of the participation rule will be dealt with harshly by the INFC Commission and will result in the removal of any and all persons involved. All coaches, assistant coaches and squads are required to attend ALL INFC season games and playoffs that are scheduled for your club. Attendance

at pre-season games and/or scrimmages and post season tournament is at the discretion of the Club Cheer Director.

Article 4: Every parent will read and sign a Parents Code of Ethics prior to any participation. It will be the responsibility of the cheer club to have the signed documents on file.

Section 10

PRACTICE & MEMBER CONDUCT REGULATIONS

Article 1: The following practice schedule will apply for all cheerleaders: (Please note that the following are maximums; if an organization wishes to reduce the amount of practice time, they may do so.)

- A mighty-mite cheerleader may practice a maximum of three days per week. Each practice shall not exceed 1 ½hour in length from the scheduled start time.
- A third or fourth grade cheerleader may practice a maximum of three days per week. Each practice shall not exceed two (2) hours in length from the scheduled start time.
- A fifth, sixth, or seventh grade cheerleader may practice a maximum of four days per week. Each practice shall not exceed two (2) hours in length from the scheduled start time.

Article 2: Members are expected to conduct themselves at organize practices, games or any function representing your prospective club and/or INFC with the utmost respect shown toward other teammates, coaches and competing teams. If a member is ejected from an INFC event, the club is to notify INFC immediately.

Article 3: Organized practice will not begin until 2 weeks prior to the set start date for INFC Tackle Football (Ref: Sec. 15, Art. 3 of INFC Football Rulebook).

Section 11

STUNT REGULATIONS AND GUIDELINES

Article 1: No stunting is allowed without a coach present. This applies to all practices, games and competitions or any function where the squad would be practicing/performing. Because of the increased athleticism of today's cheerleaders and the complexity of some stunts performed, there is a risk, as in any athletic sport, of serious injury. INFC strongly encourages all cheer clubs to provide instruction on stunting for all coaches from a stunting professional, prior to a squad being permitted to stunt, to reduce the risk(s) involved.

Article 2: ABSOLUTELY NO stunting or tumbling in wet conditions. Wet conditions are as follows: dew on grass, or raining, and/or drizzling weather.

Article 3: Any stunt above shoulder level, INFC requires a spotter at all times.

Article 4: Each organization is required to define stunt eligibility for each grade level.

Article 5: All clubs MUST provide a copy of their stunting guidelines to the INFC office prior to any practicing of stunts and/or performing of stunts can take place. Failure to comply with this rule will result in a fine, suspension of cheer squad and/or any action deemed appropriate by the INFC Commission Officers.

Article 6: INFC Cheer & Spirit Council strongly advises that each organization should obtain parent consent before any stunting be taught and/or performed.

Article 7: Due to the dangers involved with stunting, violation of any stunt rule will result in immediate and severe disciplinary action by INFC.

***** GOLDEN RULE: WHEN IN DOUBT – DON'T STUNT *****

**SEE CHART ON PAGE 57 AS AN EXAMPLE GUIDELINE
WHEN DEFINING STUNT ELIGIBILITY.**

Section 12

INFC TACKLE FOOTBALL GATE

Article 1: Everyone, including coaches and sponsors, will be required to pay gate admission or furnish an INFC game pass. If a coach or sponsor does not have their pass, he/she will be required to pay the gate admission fee.

Article 2: Any coach or person(s) caught in an attempt to gain entry with a false or reproduced INFC pass, gain entry without their pass and/or refuse to pay gate admission, or caught attempting to “hand-off” an INFC pass to another individual is subject to having their pass revoked, subject to suspension, and/or a fine up to \$100.00.

Section 13

HALF-TIME PERFORMANCES

Article 1: All cheer squads will be allowed to perform a half time routine. The cheer squad has many responsibilities during the football game; the half-time performance is one of them. Half-time is the time to motivate the crowd and get them ready for the second half.

Article 2: Half time is 10 minutes (15 minutes maximum, if necessary with prior approval from your club). Guest cheerleaders or spirit squads will perform first, followed by the home cheerleaders and/or spirit squads. Home fields are only required to allow one guest performance per half-time. No field official/field representative has the authority to cancel a half time performance without prior consent of the INFC Commissioner. ALL performances are limited to 3 minutes max.

Article 3: If half-time consists of a homecoming/recognition activity, the guest organization must be allowed to perform first and all activities cannot exceed 15 minutes combined.

Section 14

MUSIC

Article 1: Each squad MUST provide an appointed individual be in the press box during half time performance. His/her responsibility will be to announce each squad members name as well as to start and stop music for the performance. (Providing a tape recording of each squad members name might be an option).

Article 2: Each squad must have own equipment to play any music for performance.

Article 3: Please keep in mind that INFC promotes a family environment, therefore, music that contains sexual references, words and/or sounds considered inappropriate are not allowed. Dance routines that contain sexually suggestive movements are considered inappropriate and therefore not allowed.

Section 15

COMPETITIONS

Article 1: All Cheerleading & Spirit coaches will adhere to the INFC Rules and Regulations when attending all competitions. Insurance provided by INFC does not cover guidelines outside of our organization.

Article 2: All INFC football games (season and post season playoffs) are priority and must be fulfilled.

Section 16

SAFETY & APPEARANCE GUIDELINES

Article 1: Jewelry (including belly button rings), gum, or candy, are not allowed during practice or games. This rule applies to all cheerleaders, coaches and/or advisors who are actively participating at practices and games.

INFC CHEER STUNT GUIDE

	MM	3 rd	4 TH	5 th	6 th & 7 th
Thigh Stand	Y	Y	Y	Y	Y
Prep	N	Y	Y	Y	Y
Prep Torch	N	N	C	Y	Y
Prep Scorp	N	N	Y	Y	Y
Prep Aerb	N	N	Y	Y	Y
Prep to Extd	N	N	Y	Y	Y
Grd-Up Ext.	N	N	C	Y	Y
Extd Lib	N	N	N	N	C
Extd Scorp	N	N	N	N	C
Extd Scale	N	N	N	N	C
Extd Aerb	N	N	N	N	C
Bskt Toss	N	N	N	N	N
T-Tch Bskt	N	N	N	N	N
Prep F-Down	N	N	N	C	C
Ext F-Down	N	N	N	C	C
Double Down	N	N	N	N	N

Y = Approved stunt for grade level.

N = Not approved stunt. This stunt may never be attempted at stated grade level.

C = *Committee MUST be notified before stunt is attempted.*

~ Committee will attend practice, make sure stunt is taught correctly, then team is given opportunity to practice stunt.

Article 2: Fingernails, including artificial nails, must be kept at an appropriate length at practice and games to minimize the risk of injury. This rule applies to all cheerleaders, coaches and/or advisors who are actively participating at practices and games.

Article 3: Appropriate footwear must be worn at all times.

- A copy of medical releases should be kept by the coach at all practices, games, competitions, or performances.
- Be mindful when attending out of town games the location of medics, ambulances, etc.
- Prepare a quick and handy reference chart to keep with you as to who on the squad might be diabetic, allergic to bee stings, asthmatic, etc. Ask your parents to inform you of prescribed medications they may be taking.
- Make certain the squad is properly warmed-up before each practice or game. Failure to do so is one of the largest contributors to injury.
- Always inspect cheer area for debris and uneven terrain. Remove all debris from area. Keep water bottles, bags, etc. orderly and away from cheering area.

Section 17

CHEER ETIQUETTE

Article 1: It is appropriate to cheer when your team comes on the field, when your team or a player makes an exceptional play either on offense or defense, during a big defensive play, between quarters and at halftime, during timeouts, when the other team is kicking a field goal or extra point, and when your team is kicking off or punting.

Article 2: When an injured player leaves the game, it is appropriate to cheer encouragement and tribute to that player. This includes a player on the other team.

Article 3: It is not appropriate to cheer when a player is injured. This includes a player on the other team. It is advisable to take a knee until the injured player leaves the game.

Article 4: Negative, demeaning, or chanting/cheering for the purpose of taunting the opponent will not be tolerated. Applies also when more than 1 cheerleading or spirit squad is on same sideline.

Article 5: All cheer & spirit members are representing the INFC and your prospective cheer & spirit clubs so please conduct yourself in a manner that reflects good sportsmanship, a spirit of cooperation with coaches, parents and other cheerleaders as well as a care and concern for yourself and others around you.

Section 18

RULE CHANGES

Article 1: Rule changes may be amended, adopted, or repealed each season by the INFC Membership and/or Commissioner.

INDIAN NATIONS FOOTBALL CONFERENCE

CLUB MEMBERSHIP & DIRECTOR CONTACTS

BARTLESVILLE

918-336-0713

Director | Dalen Qualls
dqualls@rkymcs.com

BERRYHILL

President | Deb Stein
918-607-8137

dlbrowen@yahoo.com

VP | Amanda Slagle
918-857-1645

amandalee8585@gmail.com

BIXBY

President | John Naugle
918-812-3990

bwspartans@gmail.com

BISHOP KELLEY

President | Joe Pickard
918-691-0470

joepickard@gmail.com

VP | Brad Duffell
918-706-3484

brad.duffell@hotmail.com

M@L | Jim Huber
918-808-1627

jrhuber@sbcglobal.net

BROKEN ARROW

918-251-1015

Director | Mike Edwards
918.704.6214

edwards@youthfootball.com

CATOOSA

President | Tim White
918-671-5368

k2ctim@yahoo.com

CLUB MEMBERSHIP & DIRECTOR CONTACTS cont.

CHOCTAW

Coordinator | Aaron McConnell
620-875-1104
amconnells@yahoo.com

CLAREMORE/ C.SEQUOYAH

President | Eric Munden
918-269-3937

Asst. Director | Denis Classen
918-853-9171
inf@claremoreyouthfootball.org

COWETA

President | Randy Roberts
918-695-8237
shooters21@gmail.com

COLLINSVILLE

President | Brett Martin
918-938-1872
cyf1850@yahoo.com

VP | Jeremy Lunsford
918-779-9427

EDMOND

President | Tessa Beaulieu
405-471-4784
edmondyouthfootball@gmail.com

FORT GIBSON

President | Jacob Keeley
918-869-2034
jakeob1106@gmail.com

FB Director | Steve Atkins
918-448-5816

FB Director | John Hasler
918-616-7866
johnhaslerjr@gmail.com

CLUB MEMBERSHIP & DIRECTOR CONTACTS cont.

GLENPOOL

President | William Bartman
918-409-3792
bartmann21@gmail.com

FB Director | Bobby Standley
918-695-0780
standleybobby@yahoo.com

GROVE

President | Jane Mathia
918-314-1339
jmathia33@gmail.com

HILLDALE

President | Jack Shaffer
918-230-0749
jshaffer0412@aol.com

JENKS

President | Matthew Young
918-760-4354
matt.cmmg@icloud.com

VP | Brad Flowers
918-720-3914
b_radflowers@yahoo.com

LINCOLN CHRISTIAN

Director | Zachary Fullingim
918-892-2876
zfullingim@lincolncristianschool.com

McALESTER

President | Josh Ohls
479-459-3396
mcalesteryouthfootball@yahoo.com

VP | Coleby Lauerman
918-470-1061
coleby.lauerman@yahoo.com

CLUB MEMBERSHIP & DIRECTOR CONTACTS cont.

METRO CHRISTIAN

Director | Tyler Bacon
918-961-0445
tbacon@metroca.com

AD | Adam Taylor
918-576-1335
ataylor@metroca.com

MUSKOGEE

President | Dan Hall
918-869-2559
danhall.myfc@yahoo.com

NORMAN

President | Brandon Rehkop
brandonrehkop@att.net

FB Director | Brent Davison
405-651-9496
davisonsales@gmail.com

OWASSO

Director | Jerrod Hart
director@owassoyouthfootball.org

G.O.A.T. | Ann Kirby
918-638-0036
owassoball@aol.com

PIEDMONT

President | Jarrod Adams
316-308-2914
jarrodadams71@yahoo.com

SAND SPRINGS

President | Dustin Little
918-640-0892
coachouryouth@gmail.com

CLUB MEMBERSHIP & DIRECTOR CONTACTS cont.

SAPULPA

President | Justin Howard
918-798-0581
jhbuzz06@yahoo.com

1st VP | Scott Demauro
918-902-5980

2nd VP | Robert Brown
918-798-0581

SKIATOOK

President | Owen Collins
918-698-4460
skiatookfbclub@yahoo.com

STILLWATER

President | Tucker Barnard
tbarnard@stillwaterschools.com

FB Director | Bob Warne
405-612-0528
bobw.syfa@gmail.com

TULSA - NORTH

President | Lyndon Goff
918-402-4553
gofflyndon0378@yahoo.com

Secretary | Kelly Goff
918.951.2295
Goffkelly11@yahoo.com

TULSA - SOUTH

President | Lonnie Tolbert
918-852-5615
tulsayellowjackets@gmail.com

UNION

President | Mark Farquhar
918-289-8916
msfarquharjr@yahoo.com

Vice President | Russ Anderson
918-232-0118
russanderson@cox.net

VERDIGRIS

President | Robbie Evans
918-625-4844
robbieevans23@yahoo.com

VP | Eric Terrell
918-798-0919
etclaremore@yahoo.com

WAGONER

President | Ron Moore
918-706-5192
rlajn@windstream.net

WESTMOORE

Randy Tymchuk
405-474-2485
randytymchuk@gmail.com

YUKON

President | Daniel McKim
405-492-9108
danielmckim3@gmail.com

VP | Russell Scott
405-227-5985
scottyaviation@yahoo.com

For more information on clubs or club membership,
contact us at one of the following locaton:

INDIAN NATIONS FOOTBALL CONFERENCE
1005 S. Main St.
Broken Arrow, OK. 74012

918-251-1015
info@youthfootball.com
<http://www.inyouthsports.com>

INDIAN NATIONS FOOTBALL CONFERENCE

COMMISSIONED OFFICERS, DIRECTORS & STAFF

REGIONAL FOOTBALL DIRECTORS

TULSA - REGION

COMMISSIONER

James Dugger
918-629-8393

jdugger@americanbankok.com

VICE-COMMISSIONER

Mac McLaughlin
918-688-3336

hlmclaughlinjr@yahoo.com

OKLAHOMA CITY - REGION

COMMISSIONER

Aaron McConnell
620-875-1104

amconnells@yahoo.com

VICE-COMMISSIONER

Brent Orr
405-706-3743

brentlorr@gmail.com

SPIRIT DIRECTOR

Tasha Gilberg
918-798-3664

infcheer@youthfootball.com

CONFERENCE OFFICERS

COMMISSIONER

Chad Lott
918-251-1015
918-850-7162

chad@youthfootball.com

VICE COMMISSIONER

Brad Westmoreland
918-231-7853

bwestmor@yahoo.com

SECRETARY

Adam Taylor
918-576-1335

ataylor@metroca.com

TREASURER

Eric Munden
918-269-3937

inf@claremoreyouthfootball.org

HISTORIAN

Lyndon Goff
918-402-4553

gofflyndon0378@yahoo.com

INDIAN NATIONS FOOTBALL CONFERENCE
COMMISSIONED OFFICERS, DIRECTORS & STAFF

INDIAN NATIONS YOUTH SPORTS STAFF

BASKETBALL & LACROSSE COMMISSIONER

Michael Stroup
918-251-1015 x 1126
michaelcstroup@gmail.com

OFFICE MANAGER

Amber Goins
918-251-1015 x 1122
amber@youthfootball.com

**COMMUNICATION
COORDINATOR**

Rebekah Robinson
918-251-1015 x 1128
rebekah@youthfootball.com

HEAD OFFICIAL

Bobby Kelley
918-607-2055
bkellyok@gmail.com

LEAGUE SCHEDULER

Marty Roberson
mrrosu@cox.net

LEGAL COUNCIL

Thomas M. Askew
918-587-3161
taskew@riggsabney.com

SIGNS & SYMPTOMS OF A CONCUSSION

SIGNS OBSERVED **BY COACHING STAFF**

- Appears dazed or stunned
- Is confused about assignment or position
- Forgets sports plays
- Is unsure of game, score, or opponent
- Moves clumsily
- Answers questions slowly
- Loses consciousness (even briefly)
- Shows behavior or personality changes
- Recall events prior to hit or fall
- Can't recall events after hit or fall

SYMPTOMS REPORTED **BY ATHLETE**

- Headache or "pressure" in head
- Nausea or vomiting
- Balance problems or dizziness
- Double or blurry vision
- Sensitivity to light
- Sensitivity to noise
- Feeling sluggish, hazy, foggy, or groggy
- Concentration or memory problems
- Confusion
- Does not "feel right"

COACH RESPONSIBILITY SHOULD A CONCUSSION BE SUSPECTED

1. *Remove the athlete from play.*
 - a. Look for signs and symptoms of concussion if an athlete experienced a bump or blow to the head.
 - b. "When in doubt, sit them out" - athletes with signs or symptoms of concussion must not return to play.

2. *Ensure that the athlete is evaluated immediately by an appropriate health care professional.*
 - a. Do not try to judge the severity of the injury yourself.
 - b. Coaches recording the following can help a health care professional in assessing the athlete:
 - i. Cause of the injury and the force of the hit or blow to the head.
 - ii. Any loss of consciousness and if so, for how long.
 - iii. Any memory loss or seizures immediately following the injury.
 - v. Number of previous concussions (if any).

3. *Inform the athlete's parents/guardians of the possible concussion & and give them the concussion fact sheet for parents found on usafootball.com.*
 - a. Ensure that parents know the athlete must be seen by an appropriate healthcare professional.
 - b. Provide formal documentation of the injury and notify the league Commissioner.

4. *Allow the athlete to return to play only after an appropriate healthcare professional clears his or her return.*
 - a. A repeat concussion that occurs before the brain recovers from the first can slow recovery or increase the likelihood of having long-term problems.

PARENTS CODE OF ETHICS

I hereby pledge to provide positive support, care, and encouragement for my child participating in youth sports by following this Parents' Code of Ethics:

I will encourage good sportsmanship by demonstrating positive support for all players, coaches, and officials at every game, practice or other youth sports event.

I will place the emotional and physical well being of my child ahead of my personal desire to win.

I will insist that my child play in a safe and healthy environment.

I will require that my child's coach be trained in the responsibilities of being a youth sports coach and that the coach upholds the Coaches' Code of Ethics.

I will support coaches and officials working with my child, in order to encourage a positive and enjoyable experience for all.

I will demand a sports environment for my child that is free from drugs, tobacco, and alcohol and will refrain from their use at all youth sports events.

I will remember that the game is for youth - not adults.

I will do my very best to make youth sports fun for my child.

I will ask my child to treat other players, coaches, fans, and officials with respect regardless of race, sex, creed, or ability.

I will help my child enjoy the youth sports experience by doing whatever I can, such as being a respectful fan, assisting with coaching, or providing transportation.

I will read the National Standards For Youth Sports and do what I can to help all youth sports organizations implement and enforce them.

Signed

PARENT NAME

PARENT SIGNATURE



NFHS OFFICIAL FOOTBALL SIGNALS

1 Ball ready for play "Untimed down" 	2 Start clock 	3 Time-out Discretionary or injury time-out (followed by tapping hands on chest) 		
4 1/2-time time-out 	6 Touchdown, Field goal, Point(s) after touchdowns 	9 Safety 	7 Dead ball foul, Touchback (move side to side) 	
8 First down 	9 Loss of down 	10 Incomplete forward pass Penalty declined No play, no score Toss option deferred 	11 Legal touching of forward pass or scrimmage kick 	12 Inadvertent whistle 
13 Disregard flag 	14 End of period 	15 Sideline warning 	16 First touching (legal touching) 	17 Reset play clock to 25 seconds (give both hands to show play clock reset to 40 seconds) 
18 Encroachment 	19 False start Illegal formation Free kick infraction 	20 Illegal shift (2 hands) Illegal motion (1 hand) 	21 Delay of game 	22 Substitution infraction 



NFHS OFFICIAL FOOTBALL SIGNALS

23 Disconcerting act 	24 Illegal helmet contact Targeting 	25 Illegal horizontal tackle 	26 Illegal blindside block 	27 Unsportsmanlike conduct Noncontact foul 
28 Illegal participation 	29 Sideline interference (two arms back) 	30 Running into or Roughing kicker or holder 	31 Illegal batting/kicking (if allowed by punting award law for kicking) 	32 Illegal fair catch Illegal fair catch signal 
33 Forward pass interference Kick catching interference 	34 Roughing passer 	35 Illegal pass/forward handling (two arms back) 	36 Intentional grounding 	37 Ineligible downfield on pass 
38 Personal foul 	39 Clipping 	40 Blocking below waist 	41 Chop block 	42 Holding/ obstruction Illegal use of hands/arms 
43 Illegal block 	44 Helping runner interlocked blocking 	45 Grasping face mask or helmet spring 	46 Trapping 	47 Disqualification 

NOTES

NOTES

Indian Nations Football Conference



www.inyouthsports.com

Football - Basketball - Lacrosse - Spirit - 7v7



Indian Nations Youth Sports

1005 S. Main Street

Broken Arrow, Oklahoma 74012

p: 918-251-1015 / f: 918-258-4007 / e: info@youthfootball.com